

## OVERVIEW: RB80 EXTREME S100 SYSTEM

With the ability to achieve up to 7.8m widths, the Extreme System consists of robust hardware providing a solution for significantly heavier and impressive shading systems. The perfect solution for both internal and external applications, domestic or commercial, the extreme system creates a new opportunity to achieve greater, grander beautiful blinds.

## AESTHETIC FEATURES

- Powder coated robust die cast brackets.

## ASSEMBLY / INSTALLATION BENEFITS

- Zamack adaptor (for star head motor only) with fixing screws to ensure a secure motor attachment for large blinds.
- Round heavy duty weight bar with floating end cap for self-adjusting alignment
- Easy Wire guide tensioning at base of blind for adjustment and maintenance.
- Optional tension spring provides virtually maintenance free wire guide tension, automatically adjusting to cable stretch and contraction.
- Adjustable bearing idler
- Choice of three rigid design aluminium tube sizes; 110mm, 130mm & 160mm with simple spline and component attachment.

## FUNCTIONAL BENEFITS

- Motorised or gear control options
- Top, Face and Side fix applications.
- Heavy duty tubes & weight bar to achieve wider spans.
- Secure Stainless Steel Wire Guide System.

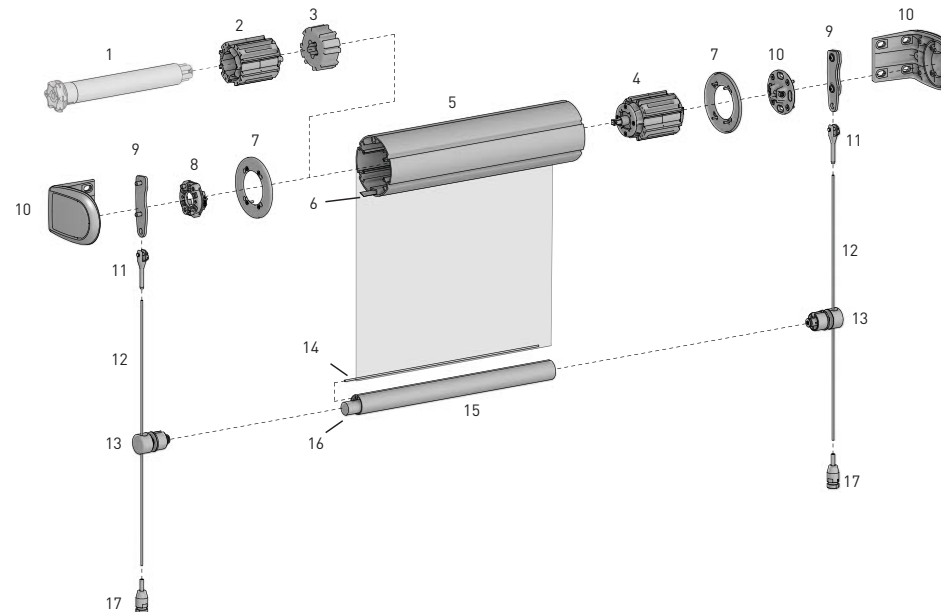

## SYSTEM OPTIONS

## SIDE FIX BRACKETS

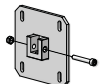

## WALL MOUNT BRACKET



## GEAR CONTROL



## SYSTEM INDEX

1	M50 Motor - SOMFY ZAMACK *
2	Extreme Universal Crown Wheel RB80-0701-073100
3	Extreme Drive Wheel RB80-0301-073100
4	Extreme Bearing Idler RB80-0201-073100
5	S100 Aluminium Tube [ STD, HD & XHD] RB93-01#0-0966#0
6	15mm Flat Spline [ OR 6mm round spline*] RB92-1501-001100
7	Extreme Tube End Plate [ STD, HD & XHD] RB80-0601-0731#0
8	SOMFY Zamack Adaptor RB56-0762-014050
9	Extreme Wire Guide Adapter - Top Fix RB80-0471-xxx100
10	Extreme Bracket Set - Top/Face Fix RB80-1201-xxx109
11	Fork Swage Terminal RE24-1314-009400
12	Stainless Steel Wire - 4mm RB91-3602-006040
13	Extreme FD42 Wire Guide End Cap RB91-1340-xxx003
14	3.5mm Round Spline *
15	Extreme FD42 Weight Bar SB06-1304-xxx600
16	Weight Bar Ballast * [max 28 Diameter]
17	Tension Bracket & Flat Head Stud Terminal RE24-2601-009040

xxx= colour    ## = size

\* Non Acmeda Item

## COLOUR RANGE

off white  
066black  
050

**SPECIFICATIONS: RB80 EXTREME S100 SYSTEM**

**BRACKET DIMENSIONS**

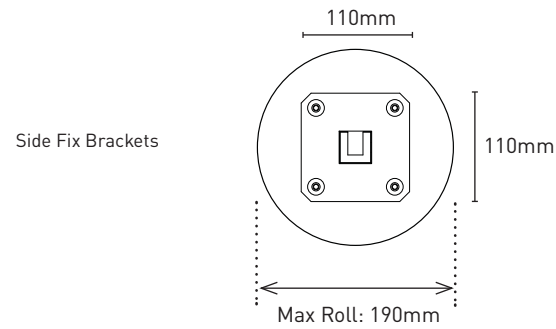
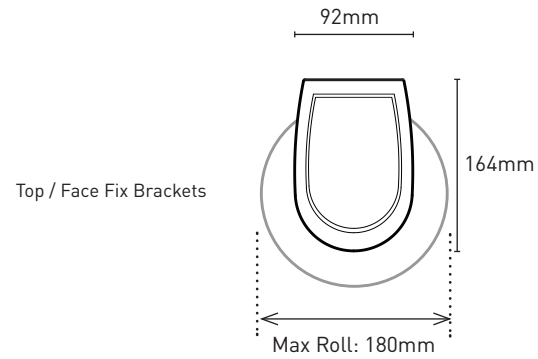

**FIXING OPTIONS**

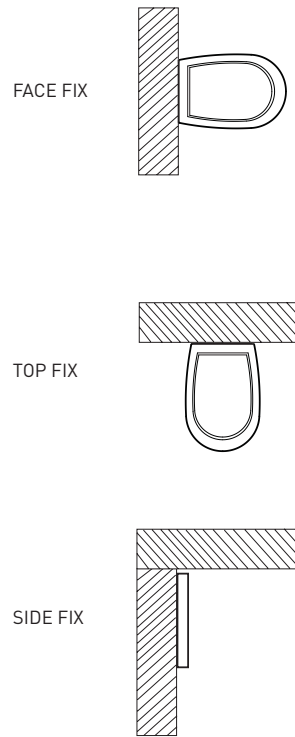

**DEDUCTIONS\***

Top/Face Fix Motorised Example Shown

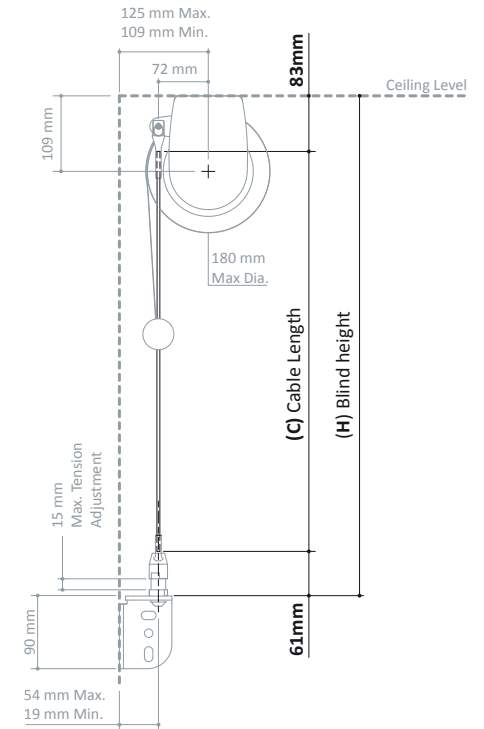

**RECOMMENDED MAXIMUM WIDTH - MOTORISED SYSTEM \***

TUBE	MAX WIDTH	MAX DROP
S100   110mm	5.6 metres	10 metres
S100   130mm	6.6 metres	10 metres
S100   160mm	7.8 metres	10 metres

**RECOMMENDED MAXIMUM WIDTH - GEAR SYSTEM \***

TUBE	MAX WIDTH	MAX DROP
S100   110mm	5.6 metres	4 metres
S100   130mm	6.6 metres	4 metres

**ALUMINIUM TUBES**

**TUBE CAPACITY CHART**

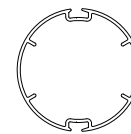
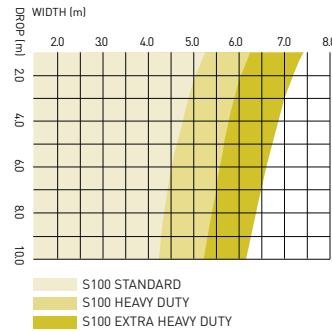

**S100 | 110 STANDARD**

CODE: RB93-0110-096600  
O.D.: 110mm  
Length: 6metres

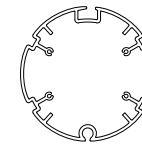

**S100 | 130 HEAVY DUTY**

CODE: RB93-0130-096700  
O.D.: 130mm  
Length: 7metres

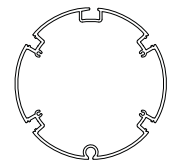

**S100 | 160 EXTRA HEAVY DUTY**

CODE: RB93-0160-096680  
O.D.: 160mm  
Length: 6.8metres

\* Refer to Product Specifications Manual for further details.