

## MC P4



Art.-no.:  
01077430

### Short description

- Microprocessor-powered motor controller for four sunshade controls
- Standard 3-wire central input
- Direct connection available for four 230VAC motors
- Connection available for group button
- Connection available for four individual buttons
- Separate connection terminals for mains supply and central transmission
- 10 different operating modes can be set, incl. inching mode and intelligent decentralised operation
- Motor run time/tilting time can be individually set
- Control via VRS radio remote control or VRS wall-mounted radio transmitter (MC P4 VRS)

### Accessories

- Control for creating sub-groups (e.g. GC 6-, GC 3-)

### Safety precautions



- Contact a professional electrician to install the control system, because the control system requires a power supply of 230VAC, 50 Hz.
- Check the control system for signs of mechanical damage after unpacking. If you notice any shipping damage, do not start up the control system and notify your supplier immediately.
- The control system should only be used for the purpose specified by the manufacturer (refer to the operating instructions). Any changes or modifications thereof are not permissible and will result in loss of all warranty claims.
- If the control unit cannot be operated without presenting a hazard, it must be switched off and prevented from being switched on unintentionally.
- When performing work on the windows, controls or connected shades, protect them against unauthorised or unintentional operation.

### Disposal of waste

The disposal of electrical equipment and batteries in household waste is strictly forbidden.



The symbol (dustbin crossed out, in line with WEEE Appendix IV) indicates separate collection of electrical and electronic products in EU countries. Do not dispose of the device or battery in your household waste. Ask your town or local council about the return and collection systems available in your area to dispose of this product.


**MC P4**  
**MC P4 VRS**  
**MC P4 Complete**  
**MC P4 Complete VRS**

Art.-no.: 01077430  
Art.-no.: 01077414  
Art.-no.: 01077431  
Art.-no.: 01077432

Programmable motor controls for operating 4 sunshade devices with group and individual controls, either wire-bound or via 868 MHz radio link.

### Installation and Operating Instructions

#### Technical data

Power supply:	230VAC, 50 Hz
Impulse voltage withstand level:	2.5 kV
Radio frequency (MC P4 VRS):	868 MHz
Rated power:	2.6 W
Fuse:	6.3 AT
Output:	230VAC, 50 Hz
Maximum load:	250VAC, 4 A, $\cos \varphi \geq 0.8$ ind.
Align switching time extend:	3 – 180 s
Align switching time retract:	180 s
Permissible motor current:	max. 6A
Software class:	A
Operating temperature:	0 °C (32 °F) to +40 °C (104 °F)
IP class:	IP 54
Degree of contamination:	2
Dimensions (L x W x H):	170 x 134 x 85 mm (without connections)
Conformity:	

#### Assembly and installation



#### WARNING!

**Risk of injury due to improper installation and commissioning.** Improper installation and commissioning may lead to personal injury or property damage.

Therefore:

- When connecting the device, observe the currently valid VDE standards (in particular DIN VDE 0100/0700), your local power company's regulations and the current accident prevention regulations.
- Connect the control in accordance with the wiring diagram.
- Only use central control with floating contact output.

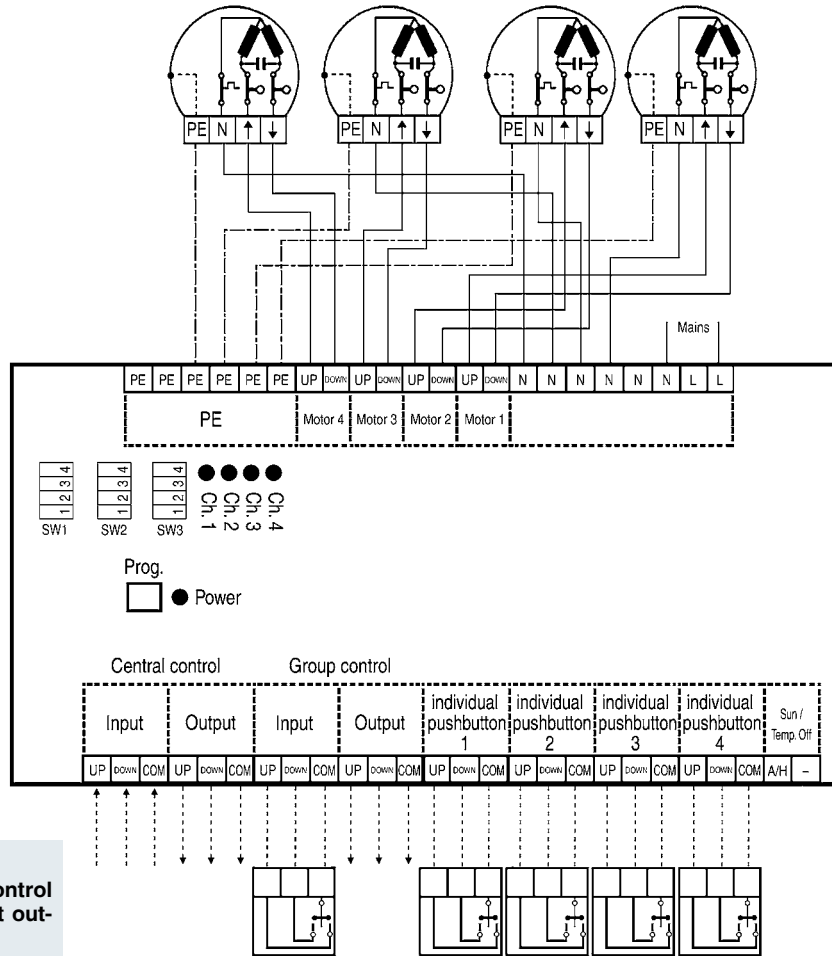
#### Notes for professional electricians

1. Switch off the power supply.
2. Undo the housing cover screws and lift off the housing cover.
3. Use the four mounting holes at the edges of the housing to mount it.
4. Connect the power supply cables and external connections according to the wiring diagram. Do not lay cables above or below the PC board.
5. Set the desired operating mode.
6. Set the desired motor run time and the tilting time, if necessary.
7. Switch on the power supply.
8. Check the motor's direction of rotation and correct it, if necessary.
9. Replace the housing cover and tighten the housing cover screws.

#### Conformity

The product meets the essential requirements of R&TTE Directive 1999/5/EC. The declaration of conformity is available on the following website:  
[www.vestamatic.com](http://www.vestamatic.com)

**Wiring Diagram**



**ATTENTION!**  
Only use central control with floating contact output.

**Operation**

**WARNING!**  
Neither group operation nor individual operation is possible while a central command is being executed.

Individual or group operation is performed by using a locked/unlocked button.

**i** The following descriptions are valid only for the radio version MC P4 VRS.

**Enter programming mode / Program VRS radio transmitter**

Press the Prog. button until the red "Ch. 1" LED flashes.  
You can now program a radio transmitter for motor 1. Programming mode will now remain open for 2 minutes. To select other channels, proceed as follows.

When the red "Ch. 1" LED flashes ⇄ :

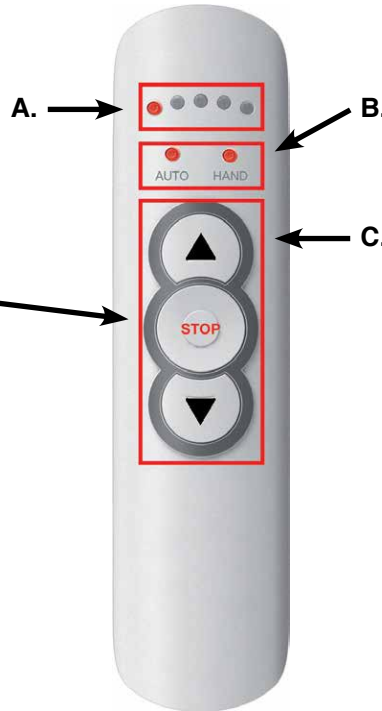
- Briefly press the Prog. button, the red "Ch. 2" LED flashes = transmitter for motor 2 can be programmed.
- Briefly press the Prog. button, the red "Ch. 3" LED flashes = transmitter for motor 3 can be programmed.
- Briefly press the Prog. button, the red "Ch. 4" LED flashes = transmitter for motor 4 can be programmed.
- Briefly press the Prog. button, the red "Ch. 1 + 2" LED flashes = transmitter for motor 1 + 2 can be programmed.
- Briefly press the Prog. button, the red "Ch. 3 + 4" LED flashes = transmitter for motor 3 + 4 can be programmed.
- Briefly press the Prog. button, the red "Ch. 1 - 4" LED flashes = transmitter for motor 1 - 4 can be programmed.

**Functions, programming and cancelling the remote control settings**

A. LED indication of selected channel of the transmitter. In total there are five channels on the transmitter.

**To change channel:**

Press and hold "stop" for 3–6s (LED start to blink), then use the ON/UP ▲ or OFF/DOWN ▼ button to select wanted channel and confirm by pressing "stop".



B. Normally used to select manual or automatic mode. Not used for this device.

C. Manual control buttons.  
 Channel 1–5 = Motor / Shade  
 Button ON/UP = ▲  
 Button STOP  
 Button OFF/DOWN = ▼

**Pair the transmitter to the control box**

Select the required switching channel on your remote control. Change channel as described above by pressing the STOP button.

Now open the MC P4 VRS programming mode. Example: Program the radio remote control to "Ch. 1" = motor 1: Press the MC P4 VRS Prog. button until the red "Ch. 1" LED flashes. Now press the ON/UP ▲, OFF/DOWN ▼ or STOP button on the radio remote control.

The 4 red LEDs on the MC P4 VRS will light up (for 1 second) to indicate that programming was successful. Motor 1 channel can now be operated.

Briefly press the ON/UP ▲ or OFF/DOWN ▼ button = inching mode

Press the ON/UP ▲ or OFF/DOWN ▼ button for more than 3 seconds = self-locking

To program more channels/transmitter, proceed appropriately.

**Cancelling the remote control settings**

Select the switching channel on your radio remote control that you wish to cancel. Change channel as described above by pressing the STOP button.

Now open the MC P4 VRS programming mode. Press the MC P4 VRS Prog. button until the channel (red LED) that you wish to cancel flashes.



Figure A

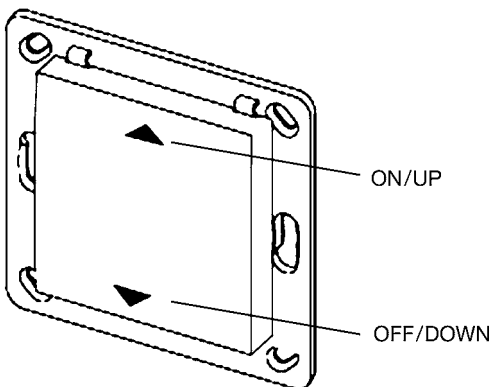
Now press the Prog. button (Fig. A) on the back of the radio remote control several times until the following LEDs flash (Fig. B).

Then press the STOP button. The 4 red LEDs on the MC P4 VRS will light up (for 1 second) to indicate that the settings have been cancelled.

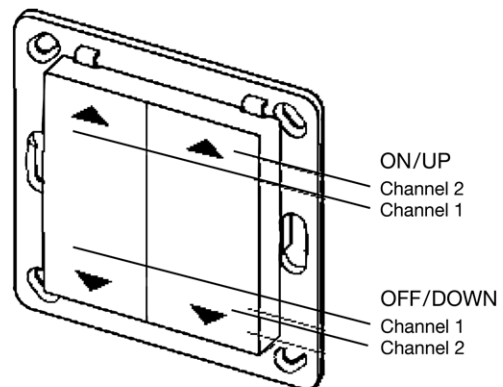


Figure B

**Functions, programming and cancelling the wall-mounted radio transmitter**



Motor control



**Programming the wall-mounted radio transmitter**

Now open the MC P4 VRS programming mode. Example: Programming the wall-mounted radio transmitter to “Ch. 1” = motor 1: Press the MC P4 VRS Prog. button until the red “Ch. 1” LED flashes. Now press the ON/UP ▲ or OFF/DOWN ▼ button on the transmitter.

The 4 red LEDs on the MC P4 VRS will light up (for 1 second) to indicate that programming was successful. Motor 1 channel can now be operated.

Briefly press the ON/UP ▲ or OFF/DOWN ▼ button = inching mode

Press the ON/UP ▲ or OFF/DOWN ▼ button for more than 3 seconds = self-locking

To program more channels/transmitter, proceed appropriately.



**Cancelling the wall-mounted radio transmitter settings**

Now open the MC P4 VRS programming mode. Press the MC P4 VRS Prog. button until the channel (red LED) that you wish to cancel flashes.

Now press the Prog. button (Fig. C) on the back of the wall-mounted radio transmitter, the red LED flashes. Now press the ON/UP ▲ or OFF/DOWN ▼ button for at least 5 seconds before releasing the button again. The 4 red LEDs on the MC P4 VRS will light up (for 1 second) to indicate that the settings have been cancelled.



Figure C



**Installation note:**

While installing the wall remote, please ensure that the arrow on the back is facing the ceiling.



The following descriptions are valid for all MC P4 versions.

**IDS Function**

The IDS (Intelligent Decentralised Sunshade control) feature enables the sun- and temperature dependant control signals on the central controls to be disabled when a button is pressed on the decentralised controls. No additional installation work is required.

In operating mode 4 the IDS-Function enables you to suppress sun- and temperature dependent extract or extend commands while all other central commands, such as for privacy and safety protection use are continuously executed. To enable this function connect a switch to terminal 31 and 32.

In operating modes 9 and 10, the sun- or temperature-dependent central commands are masked by pressing the group or individual button. All further sun- and temperature-dependent retract/extend commands will then be masked for 4 hours. Each additional operation via the group command or individual command will result in the sun- or temperature-dependent central commands being masked for a further 4 hours. After the set period has elapsed, the MC P4 control will be reset automatically and all sun- and temperature-dependent central controls will then be executed as normal.



**NOTE FOR OPERATING MODES 9 AND 10!**

Pressing the group button will block all 4 outputs for sun- and temperature-dependent central commands for 4 hours simultaneously. Pressing an individual button will only block that particular output from sun- and temperature-dependent central commands for 4 hours.

**Functional description**



**WARNING!**

The operating modes 4 to 6, 9 and 10 may only be used in conjunction with Vestamatic controls with IDS functionality.

- Operating mode 1: The group/single command will be stored after 2s; group/individual control of up to 2s will run the sunshade for the duration of the command (dead man's operation). A central command will run the sunshade for the duration of the command (dead man's operation).
- Operating mode 2: The group/single command will be stored after 5s; group/individual control of up to 5s will run the sunshade for the duration of the command (dead man's operation). A central command will run the sunshade for the duration of the command (dead man's operation).
- Operating mode 3: The group/single command will be stored immediately. A central command will run the sunshade for the duration of the command (dead man's operation).
- Operating mode 4: The group/single command will be stored after 2s; group/individual control of up to 2s will run the sunshade for the duration of the command (dead man's operation). Sun- and temperature dependent central commands can be suppressed by means of a switch at the terminals 31 and 32.
- Operating mode 5: Special function 1
- Operating mode 6: Special function 2
- Operating mode 7: The group/single command will be stored immediately. The central command will be stored immediately.
- Operating mode 8: The group/single command will be stored after 2s; group/individual control of up to 2s will run the sunshade for the duration of the command. The central command will be stored after 2s; central operation of up to 2s will run the sunshade for the duration of the command.
- Operating mode 9: The group/single command will be stored after 2s; group/individual control of up to 2s will run the sunshade for the duration of the command (dead man's operation). Sun- and temperature-dependent central commands can be suppressed for 4 hours by pressing the group or individual button.
- Operating mode 10: The group/single command will be stored immediately. Sun- and temperature-dependent central commands can be suppressed for 4 hours by pressing the group or individual button.

**Run time of the extend command**

DIP switch SW3:					
S1	S2	S3	S4	Run time	*
The duration of the retract command is always 180 s.					
OFF	OFF	OFF	OFF	5 s	
OFF	OFF	OFF	ON	10 s	
OFF	OFF	ON	OFF	15 s	
OFF	OFF	ON	ON	18 s	
OFF	ON	OFF	OFF	21 s	
OFF	ON	OFF	ON	24 s	
OFF	ON	ON	OFF	27 s	
OFF	ON	ON	ON	30 s	
ON	OFF	OFF	OFF	35 s	
ON	OFF	OFF	ON	40 s	
ON	OFF	ON	OFF	50 s	
ON	OFF	ON	ON	60 s	
ON	ON	OFF	OFF	80 s	
ON	ON	OFF	ON	100 s	
ON	ON	ON	OFF	120 s	
<b>ON</b>	<b>ON</b>	<b>ON</b>	<b>ON</b>	<b>180 s</b>	<b>default settings</b>

\* This is where you can note your project-specific basic settings.

**Operating mode**

DIP switch SW1:							
S1	S2	S3	S4	Operating mode		Tilting	*
				No.	Application		
OFF	OFF	OFF	OFF	1	standard venetian blinds / curtain blinds	possible only via central command	
OFF	OFF	OFF	ON	2	venetian blinds / curtain blinds with slow start velocity	possible only via central command	
OFF	OFF	ON	OFF	3	roller shutters	possible only via central command	
OFF	OFF	ON	ON	4	IDS venetian bl./curtain bl. with autom. interlock	adjustable, 0 – 2 s	
OFF	ON	OFF	OFF	5	IDS spec. venetian blinds/ curtain blinds special function 1	adjustable, 0 – 5 s	
OFF	ON	OFF	ON	6	IDS spec. venetian blinds/ curtain blinds special function 2	adjustable, 0 – 2 s	
OFF	ON	ON	OFF	7	roller shutters	no tilting possible	
OFF	ON	ON	ON	8	venetian blinds without slow start velocity	possible only via central command	
ON	OFF	OFF	OFF	9	IDS venetian blinds/ curtain blinds 4 h locking	adjustable, 0 – 2 s	
ON	OFF	OFF	ON	10	IDS venetian blinds/ curtain blinds 4 h locking	adjustable, 0 – 2 s	

**Tilting time**

Depending on the operating mode selected one of the following tables shall apply for setting the required tilting time. The tilting time will only be executed after a central command!

**Tilting time table f. operating mode 4, 6, 9, 10**

DIP switch SW2:					
S1	S2	S3	S4	Tilting time	*
OFF	OFF	OFF	OFF	no tilting	
OFF	OFF	OFF	ON	0.1 s	
OFF	OFF	ON	OFF	0.2 s	
OFF	OFF	ON	ON	0.3 s	
OFF	ON	OFF	OFF	0.4 s	
OFF	ON	OFF	ON	0.5 s	
OFF	ON	ON	OFF	0.6 s	
OFF	ON	ON	ON	0.7 s	
ON	OFF	OFF	OFF	0.8 s	
ON	OFF	OFF	ON	0.9 s	
ON	OFF	ON	OFF	1.0 s	
ON	OFF	ON	ON	1.2 s	
ON	ON	OFF	OFF	1.4 s	
ON	ON	OFF	ON	1.6 s	
ON	ON	ON	OFF	1.8 s	
ON	ON	ON	ON	2.0 s	

\* This is where you can note your project-specific basic settings.

**Tilting time table for operating mode 5**

DIP switch SW2:					
S1	S2	S3	S4	Tilting time	*
OFF	OFF	OFF	OFF	no tilting	
OFF	OFF	OFF	ON	0.4 s	
OFF	OFF	ON	OFF	0.7 s	
OFF	OFF	ON	ON	1.0 s	
OFF	ON	OFF	OFF	1.3 s	
OFF	ON	OFF	ON	1.6 s	
OFF	ON	ON	OFF	1.9 s	
OFF	ON	ON	ON	2.2 s	
ON	OFF	OFF	OFF	2.5 s	
ON	OFF	OFF	ON	2.8 s	
ON	OFF	ON	OFF	3.1 s	
ON	OFF	ON	ON	3.4 s	
ON	ON	OFF	OFF	3.7 s	
ON	ON	OFF	ON	4.0 s	
ON	ON	ON	OFF	4.5 s	
ON	ON	ON	ON	5.0 s	